



est. 1987  
**Magnolia**HOMES

OAK HILL

# The Willow

## BASE PLAN



ELEVATION A



ELEVATION B



ELEVATION C



ELEVATION D

### Oak Hill

HEATED SQ. FT. 4753 PLUS  
SQ. FT. UNDER ROOF 4844 PLUS

5 BEDROOMS (2 DOWN)  
4 FULL BATHS  
REC ROOM UPSTAIRS  
2 CAR GARAGE  
MEDIA ROOM UPSTAIRS  
COVERED PORCH ON REAR OF HOME

#### Available Options to Add:

- BUILT-INS IN FAMILY ROOM
- BASE CABINETS IN LAUNDRY ROOM
- BUTLER'S PANTRY IN BREAKFAST AREA
- THIRD CAR GARAGE
- HALF BATH DOWNSTAIRS
- WALK THROUGH SHOWER IN PRIMARY BATHROOM
- EXPANDED OUTDOOR LIVING SPACE WITH FIREPLACE

#### Included:

- JAMES HARDIE® (NO ROT) SIDING WITH A 30 YR. MANUFACTURER LIMITED WARRANTY, EXTERIOR TRIM HAS A 15 YR. LIMITED WARRANTY; PER PLAN.
- PELLA® WINDOWS ARE LOW-MAINTENANCE VINYL FRAMED WINDOWS = NO MORE PAINTING. LOW-E ADVANCED GLASS & ARGON GAS IN ALL WINDOWS. SDL WINDOWS ON FRONT OF HOME & WINDOWS FACING STREET.
- AMANA® EQUIPMENT USED FOR HVAC, LTD. LIFETIME WARRANTY ON COMPRESSOR AND HEAT EXCHANGE WITH 10 YR. PARTS FOR THE ORIGINAL HOMEOWNER.





est. 1987  
**MagnoliaHOMES**

OAK HILL

# The Willow

## BASE PLAN

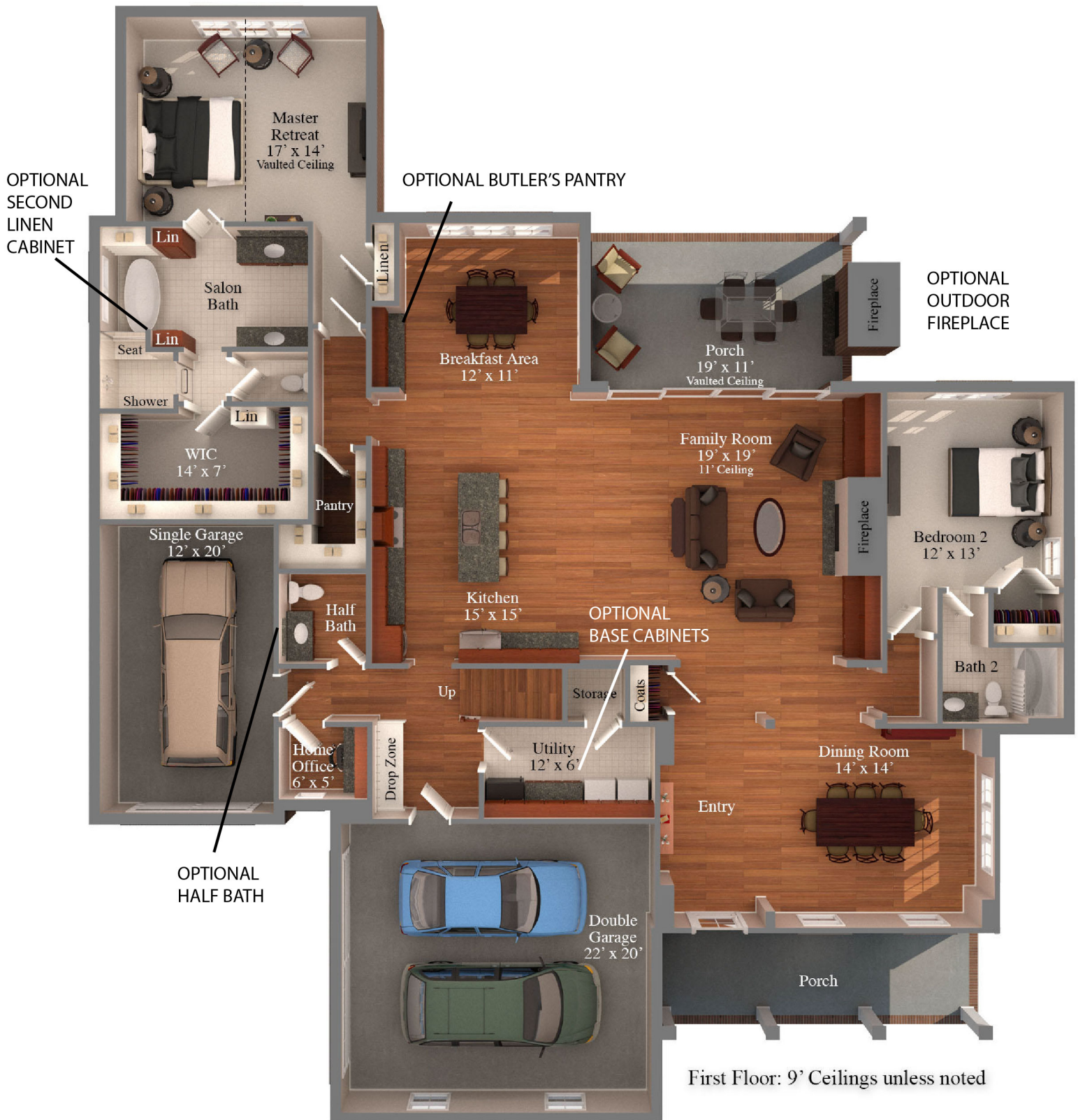

First Floor: 9' Ceilings unless noted



est. 1987  
**Magnolia**HOMES

OAK HILL

# The Willow

## BASE PLAN

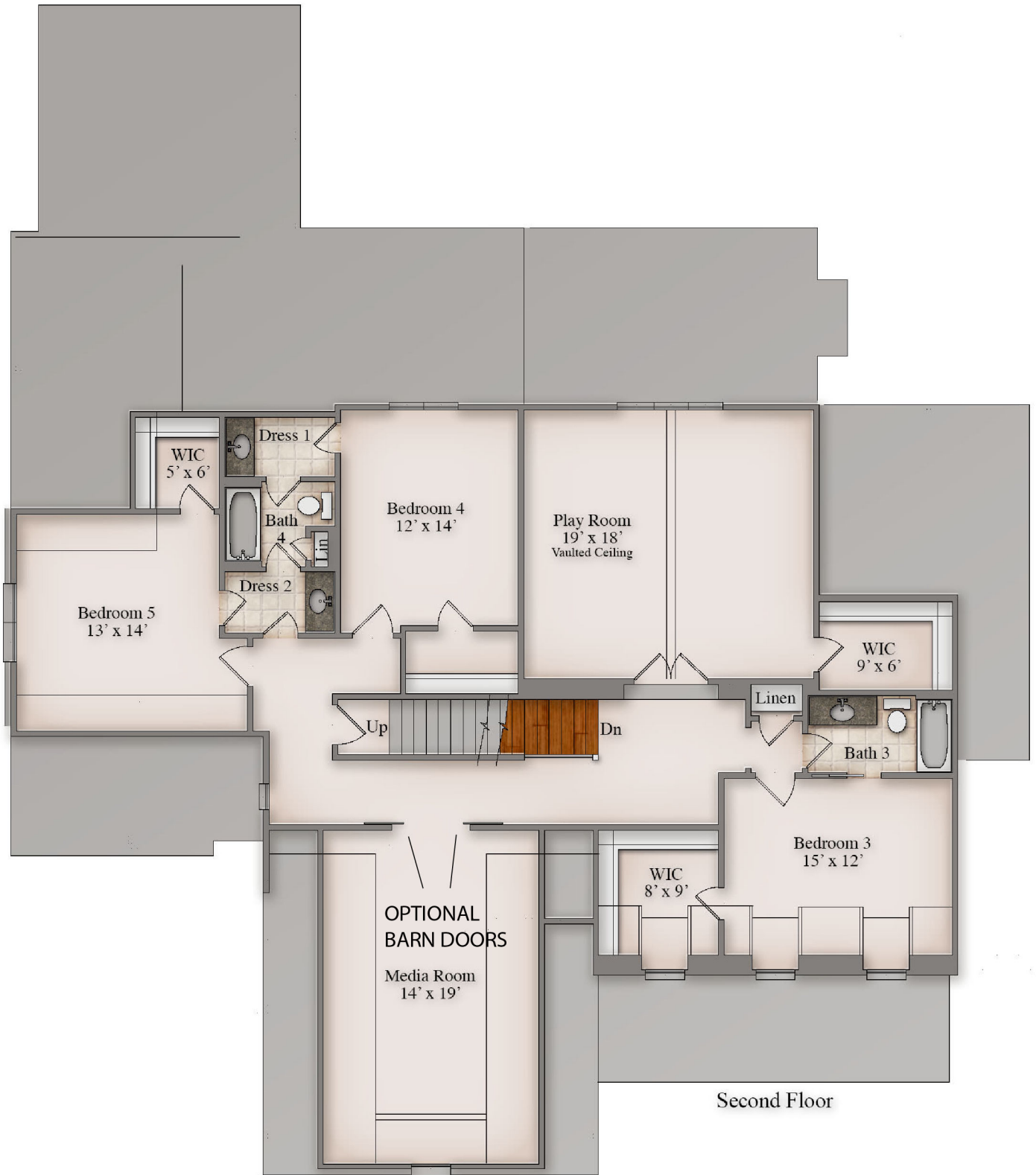



est. 1987  
**MagnoliaHOMES**

OAK HILL

# The Willow

## BASE PLAN



OPTIONAL  
WALK-THRU  
SHOWER

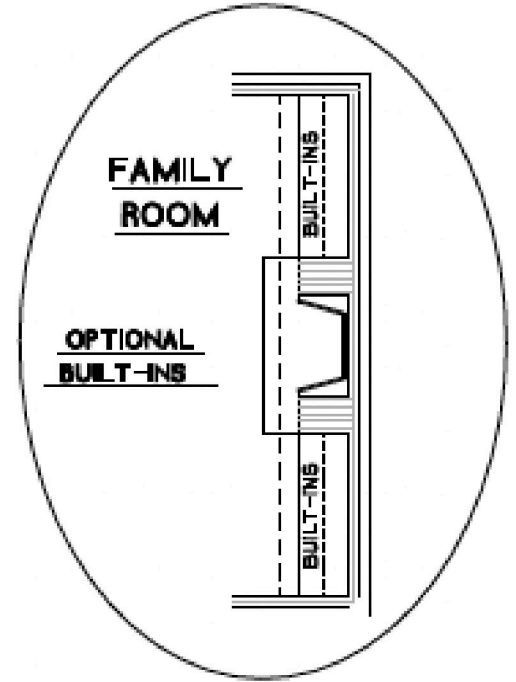

FAMILY  
ROOM  
  
OPTIONAL  
BUILT-INS

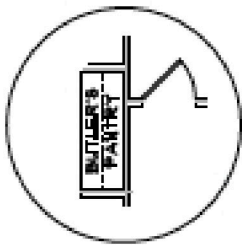

OPTIONAL  
BUTLER'S PANTRY

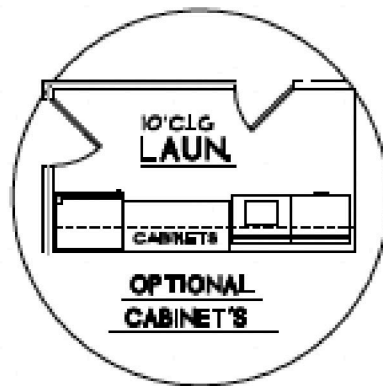

OPTIONAL  
CABINET'S

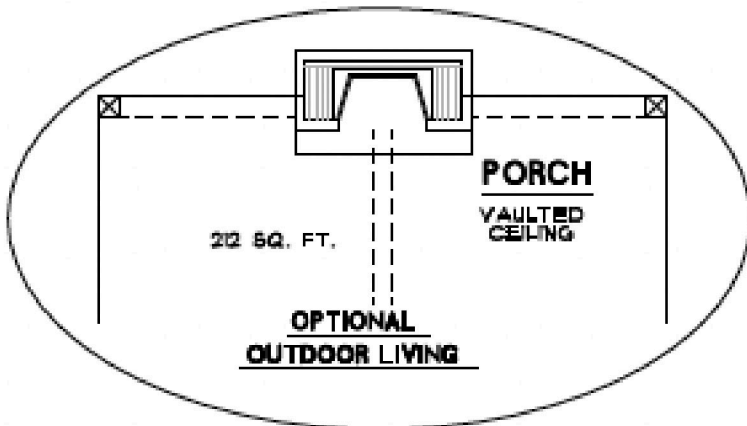

OPTIONAL  
OUTDOOR LIVING

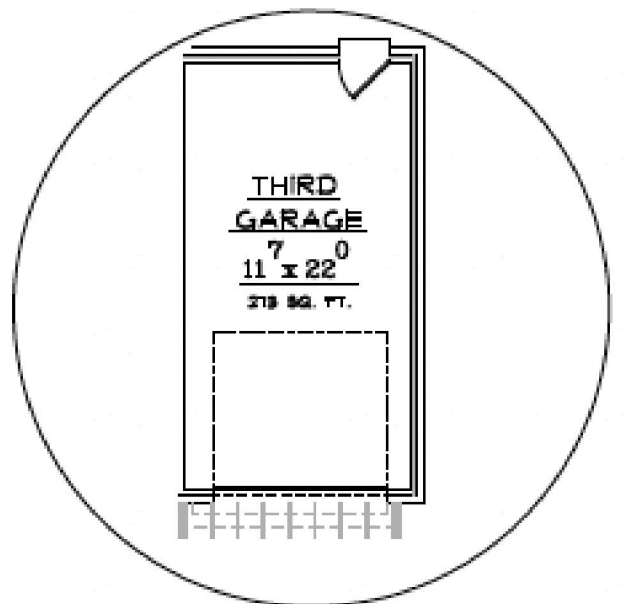

OPTIONAL  
THIRD GARAGE