



est. 1987  
**Magnolia**HOMES

VILLAGES OF SAUNDERS CREEK

# The Myers plan



ELEVATION A



ELEVATION B



*Villages of Saunders*

HEATED SQ. FT. 3232-3482  
SQ. FT. UNDER ROOF 3927-4377

9' CEILINGS DOWNSTAIRS\*  
4 BEDROOMS INCLUDED  
2 BEDROOMS DOWN  
3 FULL BATHROOMS  
BREAKFAST ROOM  
2 STORY FOYER  
LOFT AREA UPSTAIRS  
GAME ROOM UPSTAIRS  
DOUBLE GARAGE  
COVERED PORCH ON REAR OF HOME

### *Available options to add:*

- HALF BATH OPTION DOWNSTAIRS
- OPTIONAL THIRD CAR GARAGE; INCLUDING AREA ABOVE TO BE FINISHED
- OPTIONAL EXPANDED BREAKFAST AREA AND MASTER CLOSET
- OPTIONAL DOUBLE CLOSETS IN MASTER BATH

### *Included:*

- JAMES HARDIE® (NO ROT) SIDING WITH A 30 YR. MANUFACTURER LIMITED WARRANTY, EXTERIOR TRIM HAS A 15 YR. LIMITED WARRANTY; PER PLAN.
- PELLA® WINDOWS ARE LOW-MAINTENANCE VINYL FRAMED WINDOWS = NO MORE PAINTING. LOW-E ADVANCED GLASS & ARGON GAS IN ALL WINDOWS. SDL WINDOWS ON FRONT OF HOME & WINDOWS FACING STREET.
- AMANA® EQUIPMENT USED FOR HVAC, LTD. LIFETIME WARRANTY ON COMPRESSOR AND HEAT EXCHANGE WITH 10 YR. PARTS FOR THE ORIGINAL HOMEOWNER.





est. 1987  
**Magnolia**HOMES

VILLAGES OF SAUNDERS CREEK

# The Myers plan





# The Myers plan

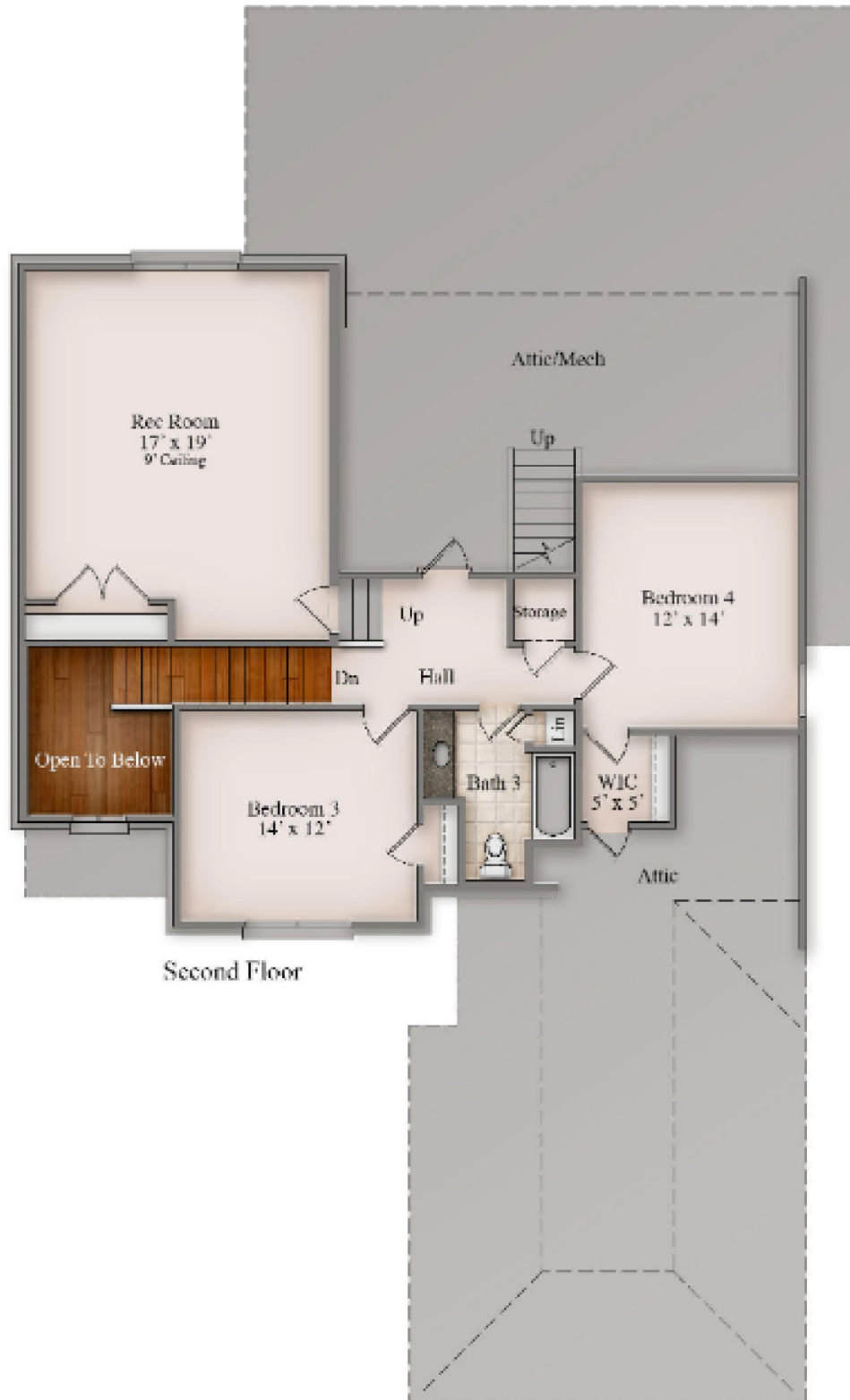



est. 1987  
**Magnolia**HOMES

VILLAGES OF SAUNDERS CREEK

# The Myers plan

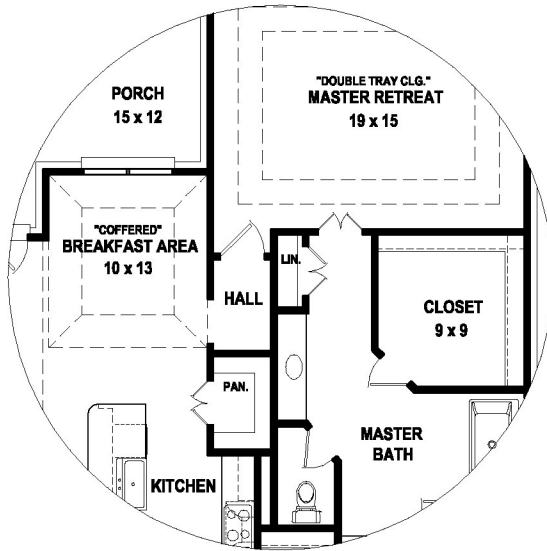

**"OPTIONAL"  
EXPANDED BREAKFAST  
AREA AND MASTER CLOSET**

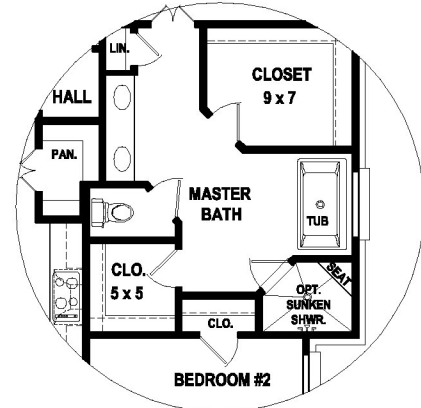

**"OPTIONAL"  
DOUBLE CLOSETS IN MASTER BATH**

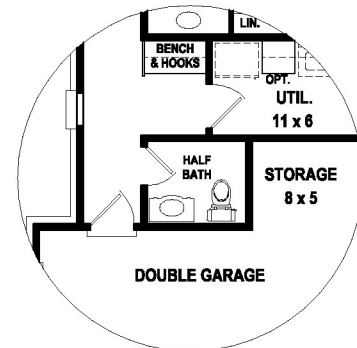

**"OPTIONAL"  
HALF BATH**

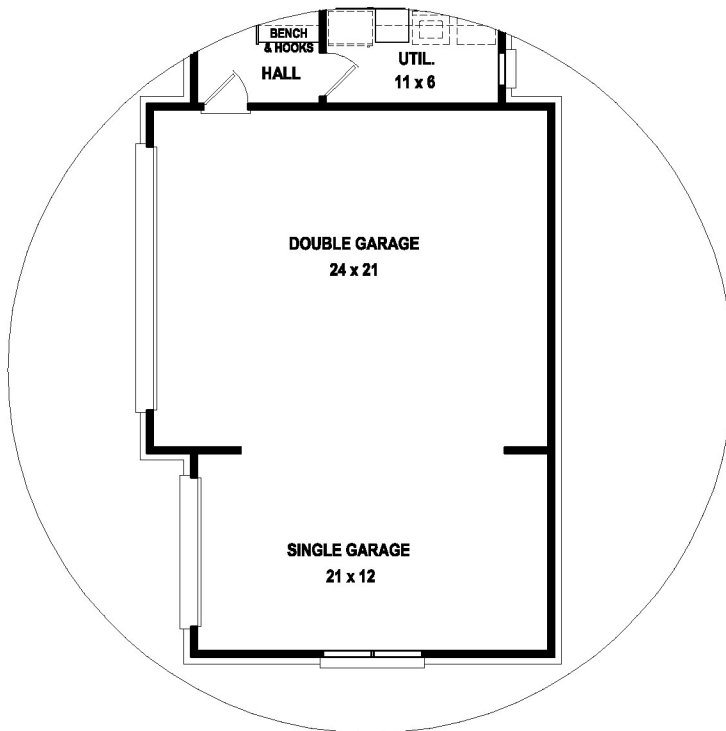

**"OPTIONAL"  
EXPANDED  
TRIPLE GARAGE**

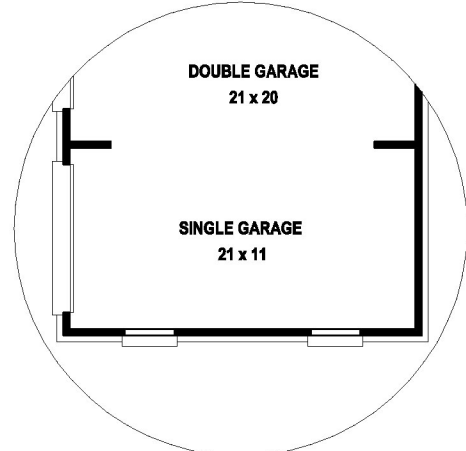

**"OPTIONAL"  
TRIPLE GARAGE**